

# locker showcase cabinet Finn

OP-5852-VZEN

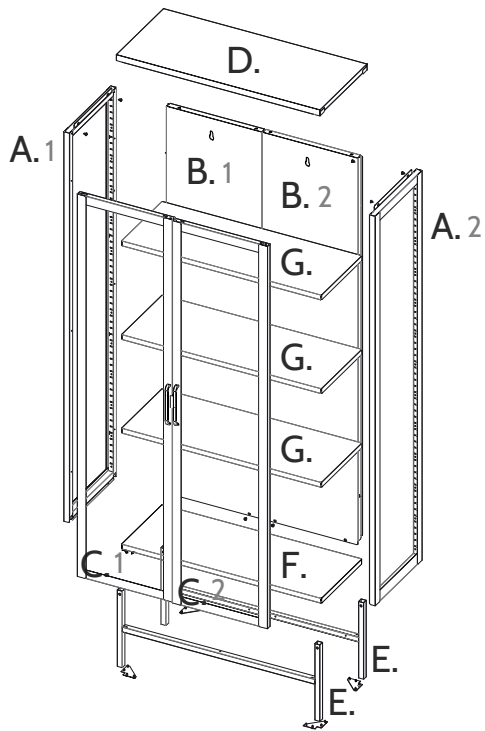

1. 37x

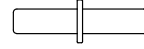

2. 2x



3. 2x



4. 12x

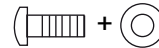

5. 4x



6. 2x



7. 4x

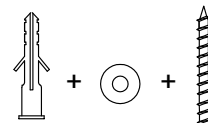

8. 2x



9. 6x

*Tip!*

Be sure to carefully unpack the parts and place them on a soft surface, such as a blanket. Then check all parts for damage before you begin assembly. Assembled products cannot be returned.

1

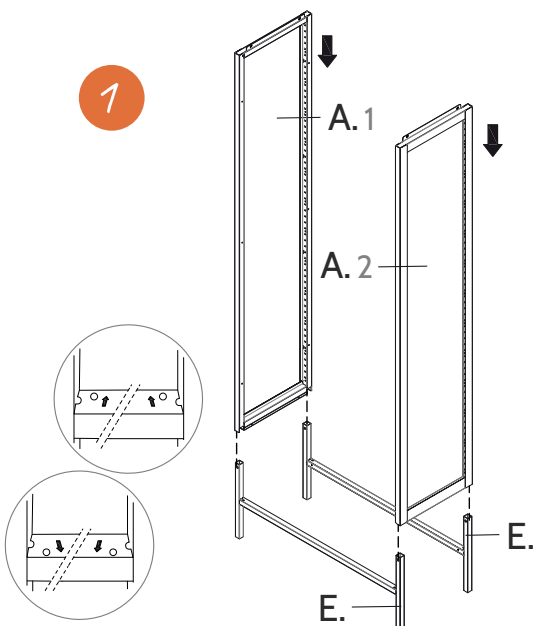

Attention: Holes must face outwards, plastic levelling feet must face down.

2

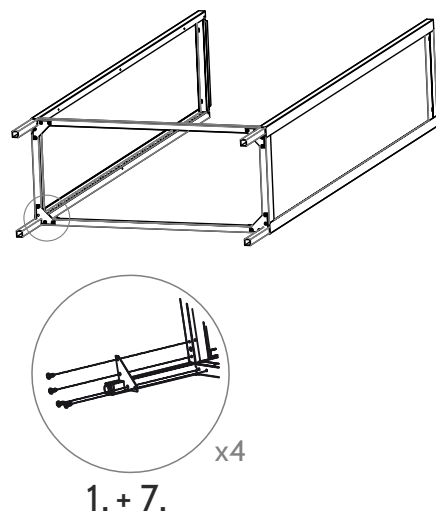

1. + 7.

Lightly tighten screws. Once all 4 corners have been attached, you can tighten them.

# locker showcase cabinet Finn

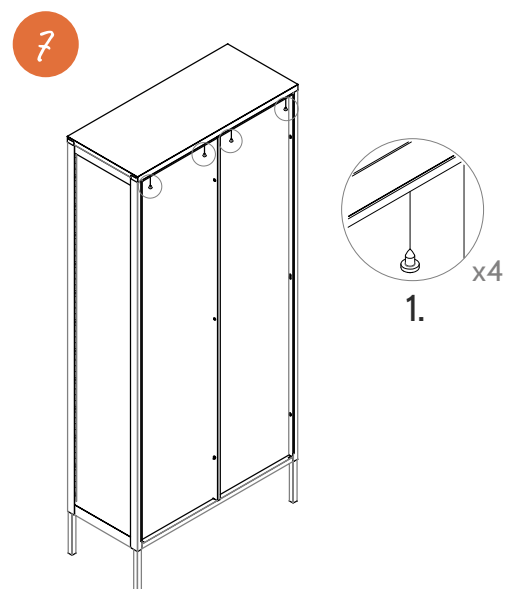
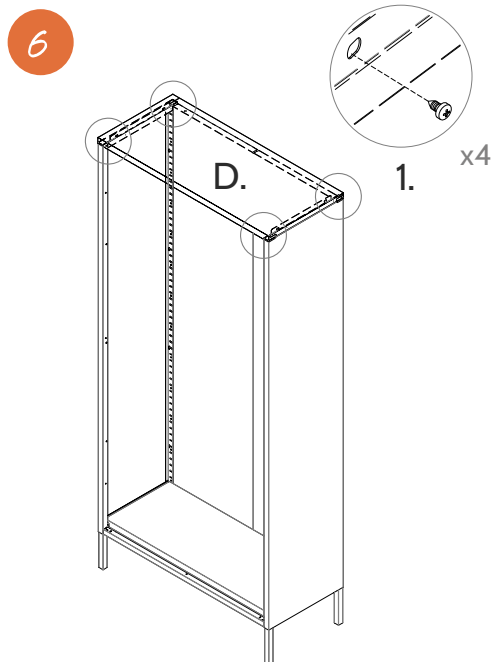
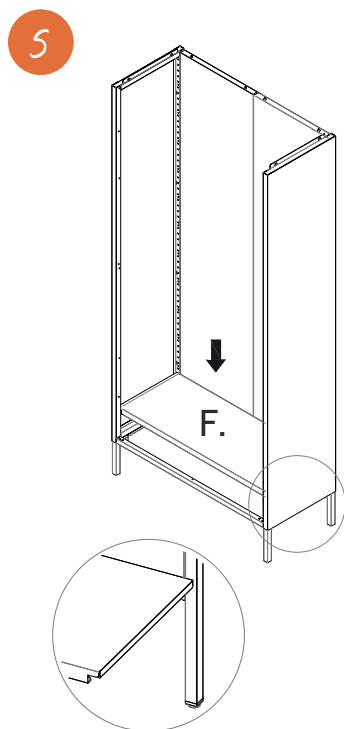
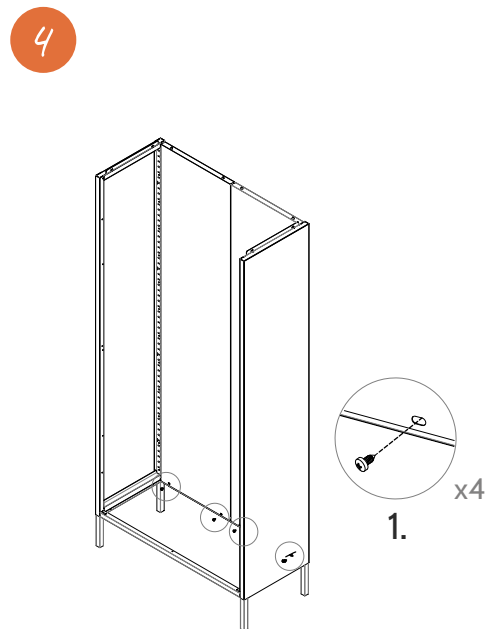
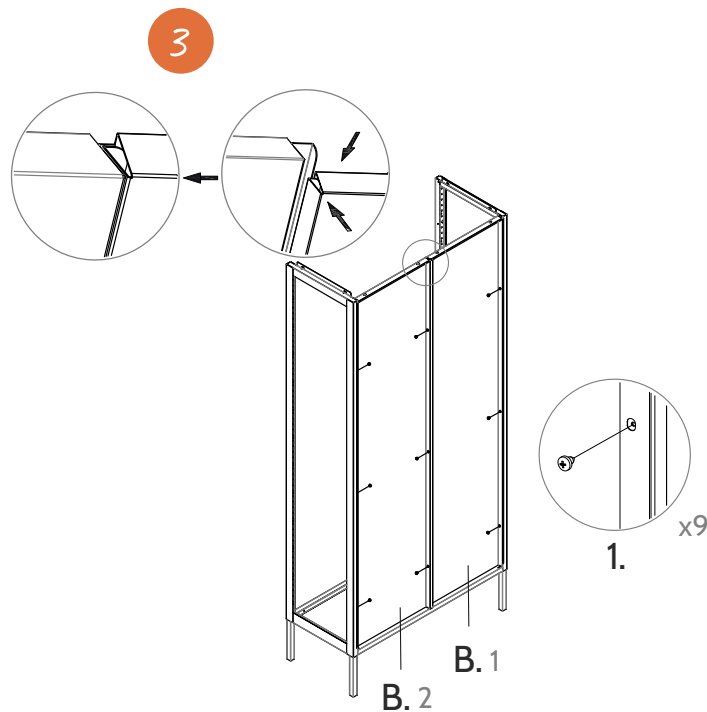

Attention! Place the top with the holes towards the back. (see step 13)

# locker showcase cabinet Finn

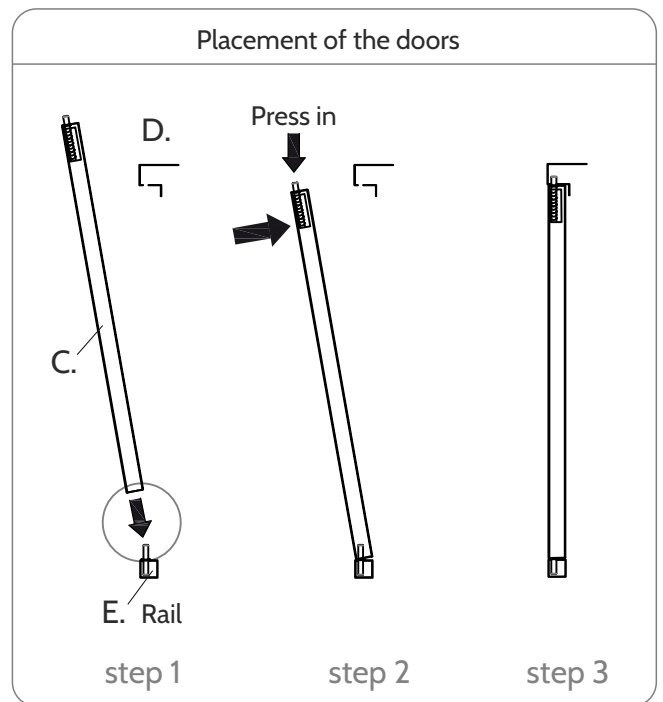
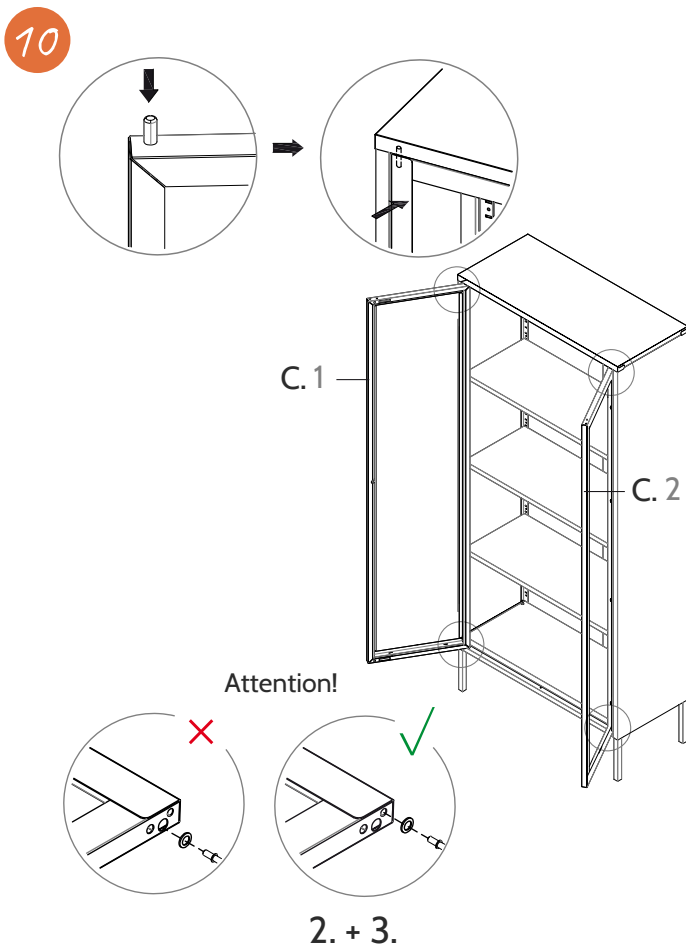
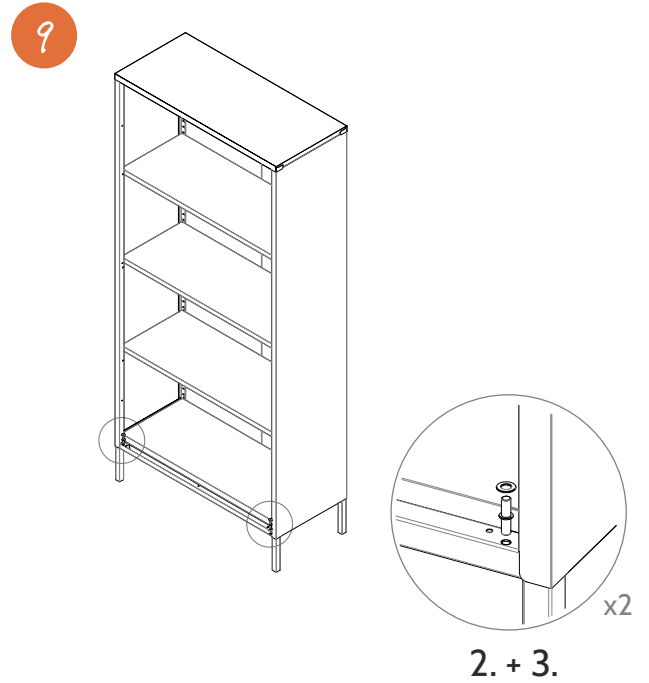
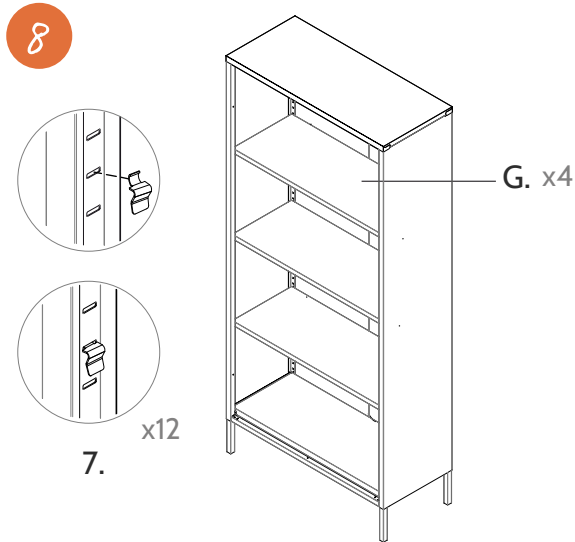

# locker showcase cabinet Finn

11

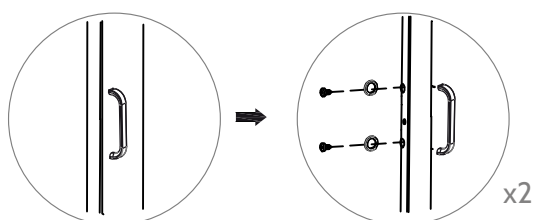

5. + 6.

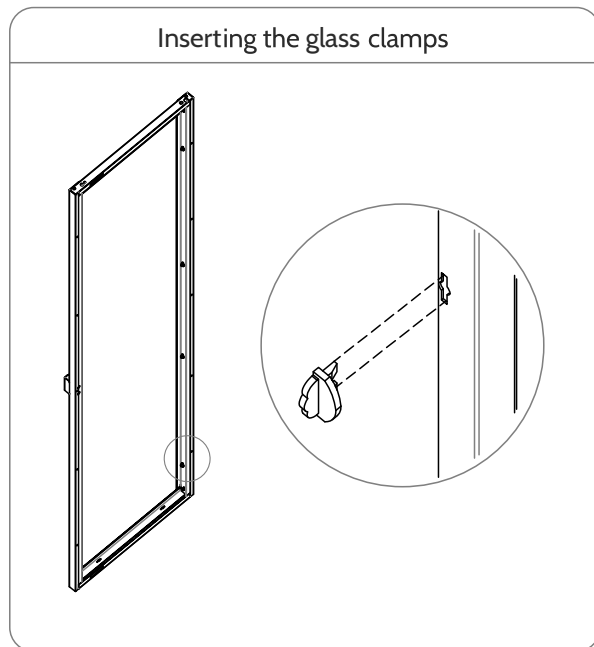
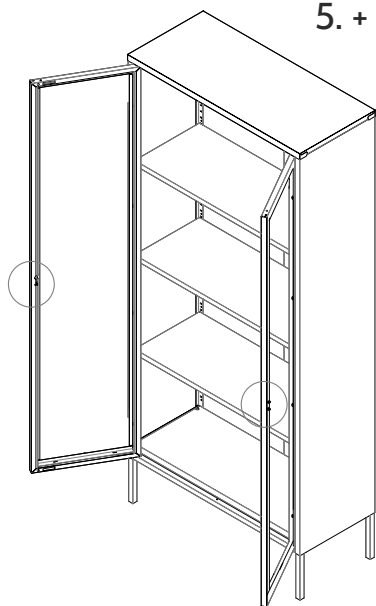

12

Turn the levelling feet to correct.

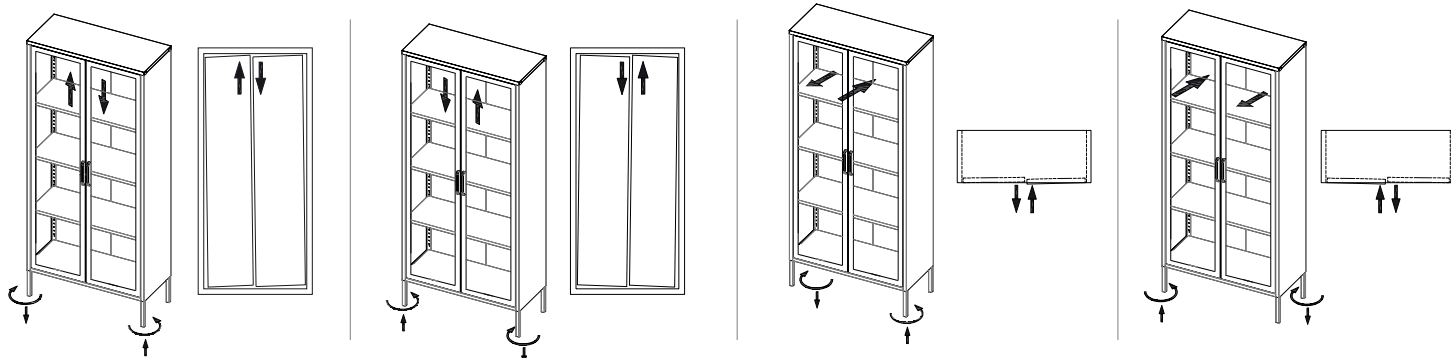
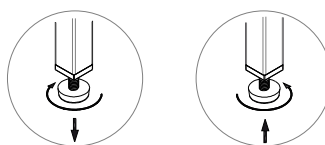

13

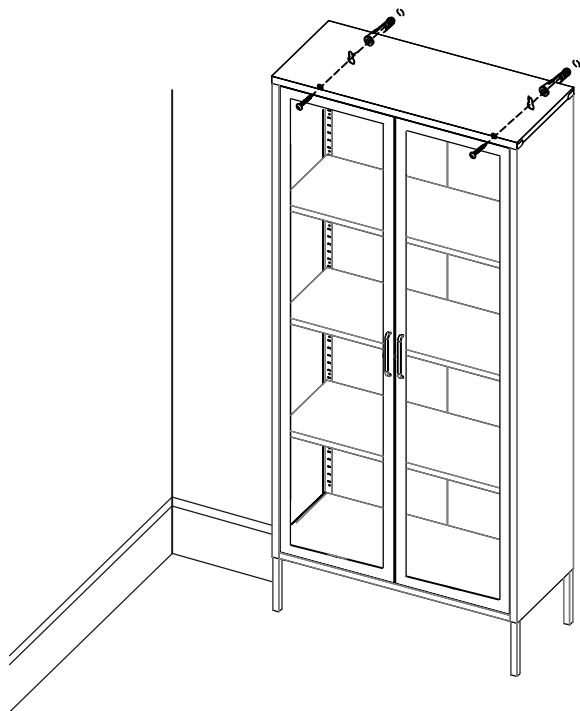
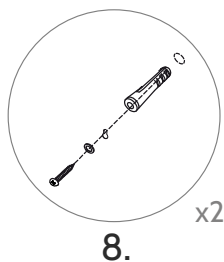

### Removing the doors

Attention! This step is for disassembly only

